

Switcher & Shortline Locomotive Family



SWM9 Mid-Cab Series
Switcher, Mid-mount cab 82 ton 900 hp



SWR18 Rear-Cab Series
Switcher, Rear-mount cab 120-180 ton 1850 hp

Images may be shown with Optional Equipment

Integral dx Shortline Locomotive Family

Model	Type	Configuration	Horsepower	Weight (Ton)
SWM9	Switcher Locomotive	Mid Mount Cab	900	82
SWR10 / SWF10	Switcher Locomotive	Rear Mount Cab / Front Mount Cab	1000	120-180
SWR16 / SWF16	Switcher Locomotive	Rear Mount Cab / Front Mount Cab	1600	120-180
SWR18 / SWF18	Switcher Locomotive	Rear Mount Cab / Front Mount Cab	1800	120-180
SWR21 / SWF21	Switcher Locomotive	Rear Mount Cab / Front Mount Cab	2100	120-180

A Letter From the CEO



Interested Locomotive Customer,

Our 28 year old companies are well known in many equipment markets, including the Railroad Maintenance of Way market. We have touched and influenced over 300,000 self-propelled pieces of equipment, including nearly 300 complex railroad car design & builds. Many of these from a clean sheet of paper, through entire design and analysis, and review of all relevant standards.

In 2023 the Navy was seeking someone to design a clean sheet Switcher Locomotive that matched the 1954 GE80 style and performance. We leaped at this opportunity, and inside of 18 months we demonstrated meeting all the AAR-NEC-ISO-ANSI-AWS-CFR related Locomotive specifications. We incorporated proven prime movers, Marathon generators, traction controls, and undercarriage components. Of course, we ultimately built the first units in our AAR certified facility. The following pages will show you the details of each design subsystem.

In 2024 the Air Force followed the Navy and asked that we provide a modern design for something similar to a GP-9. What was interesting here, was the GEEP New Build could utilize many of the same designs we utilized for the GE80 900 Hp Modernized New Build design, but with an upsized Cat Tier 4f diesel prime mover. After all, the EMD D77/78 placed under the 900 Hp were capable of 2100 Hp prime movers.

From this GEEP Army award, a family was born. Our cab is designed to be mid ship, rear, or front mounted. The generators are sized to match to the 900 Hp to 2100 Hp optional prime mover diesel Tier 4f engines. Propel & Traction controls allow for correct power ratings to the tractive drives, and we place the EMD 77/78 under all of our locomotives. Design the overall weight from 82 tons to 180 tons, 45 feet in Length Overall All (LOA) to 55 feet in LOA, and you have a family of Locomotives.

Yes, we are a new brand to the locomotive industry, but do not let anyone tell you we are a startup. We have co-built and/or turn-key built locomotives & power cars with several industry leaders, including Progress Rail and RJ Corman.

Thank you for considering the first family of New Design & New Build 900 Hp to 2100 Hp Locomotives in over 60 years. This range of offering is perfect for Switcher Locomotives or Short Line Locomotives.

Kevin R. Wald

Kevin R. Wald
CEO



Our Vision: Embrace those who respect, honor, and value relationships



The Family of Switcher Locomotives & Short Line Locomotives Details

Fuel & DEF

- Selectable 400 gallon, 600 gallon, or 800 gallon diesel fuel tanks
 - Other sizes available upon request, and per ability to fit underside frame
- 900 Hp - 1200 Hp require DEF

Truck Assemblies & Traction Motors

- AAR Switcher Trucks with EMD D77/D78 Traction Motors
- Optional Blomberg B (Swing Hanger) Trucks with EMD D77/D78 Traction Motors

Braking

- New York Airbrake CCB-26 certified system
- Optional New York Airbrake CCBII (computer controlled brake) recommended for passenger trains

Selectable Cab Mount Configuration: Mid, Rear, or Front

- High Voltage Cabinet is inside Mid Mount Cab
- High Voltage Cabinet is outside Rear & Front Cabs, in a NEMA Enclosure
- Cab HVAC maintains 68° F to 72° F in temps 0° F to 100° F ambient

Selectable Prime Movers, Twin Engines

Engine Brand	Model	Engine Config.	Engine HP	Total HP	Regulatory
Caterpillar	C9.3B	2	335-456	670-912	Tier 4F
Caterpillar	C13B	2	456-577	912-1154	Tier 4F
Caterpillar	C18	2	575-800	1150-1600	Tier 4F
Caterpillar	C27	2	800-1050	1600-2100	Tier 4F

Generator Matched to Engine Selection

Generator Brand	Model	Engine HP	Volt AC	Amperage
Marathon	574RDL	900	315-480 3 Phase	600 Cont/1200 P
Marathon	574RDL	1000	315-480 3 Phase	600 Cont/1200 P
Marathon	741RSL	1600	315-480 3 Phase	600 Cont/1300 P
Marathon	743RSL	1800	315-480 3 Phase	700 Cont/1500 P
Marathon	744RSL	2100	315-480 3 Phase	900 Cont/1500 P

Traction Controls & Operators Stand

- Integrated TMV traction controls
- American Traction Systems (ATS) with DLL components
- Custom design and coded IFM control Human Machine Interfaces (HMI)
- All developed to leverage J1939 CAN bus protocols throughout
- Integration of standard locomotive controls per AAR utilizing standard 8-notch propel settings
- Integrated with the standard 27 pin Multi-Unit (MU) locomotive capabilities

Compressor

- Atlas Copco GAR-30 (120 CFM) or Atlas Copco GAR-37 (160 CFM)
- Optional Gardner Denver 170 CFM to 213 CFM
- Optional NYAB 120 CFM

Speed & Draw Bar Pull

- 60 Mph+ on all units
- 40,000 lb draw bar pull 82 Ton, Mid Mount Cab
- 58,000 lb draw bar pull 120 Ton, R/F Mount Cab
- 68,000 lb draw bar pull 140 Ton, R/F Mount Cab
- 80,000 lb draw bar pull 180 Ton, R/F Mount Cab

Compliance

- AAR, NEC, NFPA, FRA, ANSI, SAE, ISO, EPA, CARB as Applicable
- (CFR) Title 49, Part 223 Safety Glazing Standards
- (CFR) Title 49, Part 224 Reflectorization of Rail Freight Rolling Stock
- (CFR) Title 49, Part 229 Railroad Locomotive Safety Standards
- (CFR) Title 49, Part 231 Railroad Safety Appliance Standards
- (CFR) Title 49, Part 232 Brake System Safety Standards
- American Welding Society D15.1 - Railroad Welding Specification
- Manufactured in an AAR Certified Facility
- All Ritalka Companies are ISO 9001:2015 Certified
- A detailed list of standard compliance available upon request

*Materials and specifications are subject to change without notice.
 Featured machines in photos may include additional equipment.
 Speed and draw bar pull specifications will vary based on conditions.*

Locomotive Layout & Dimensions

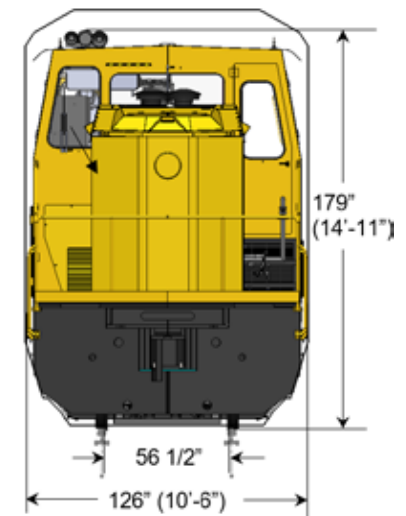
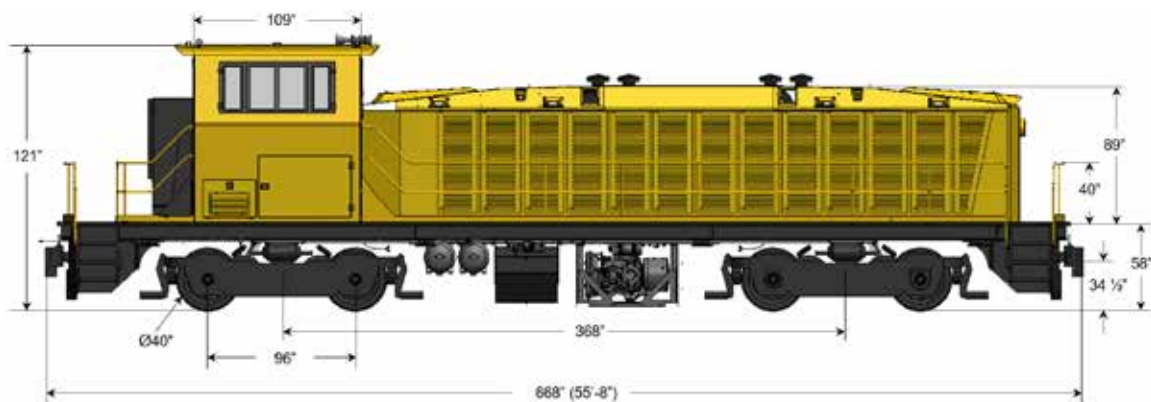
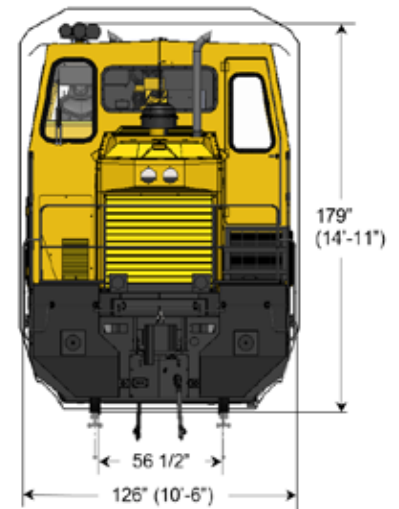
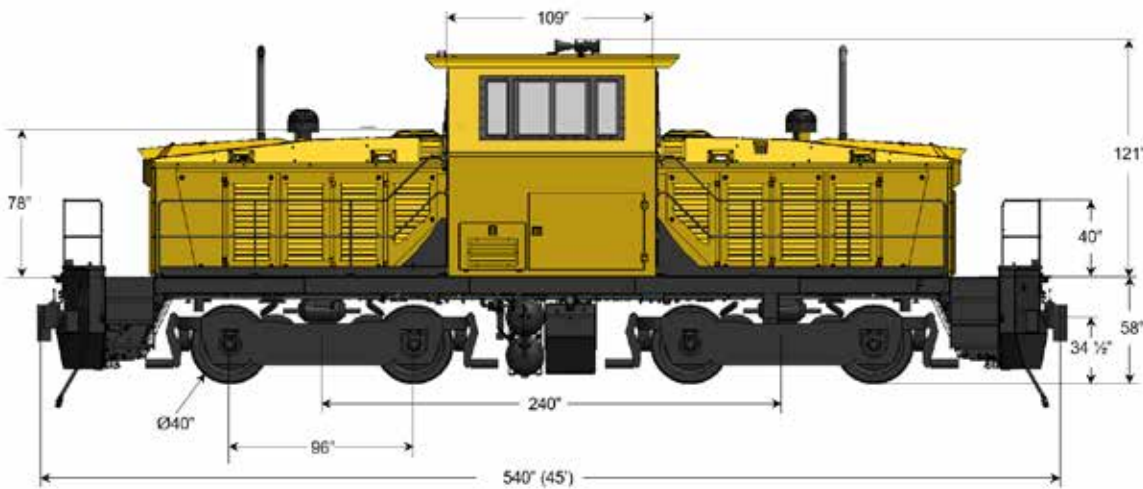
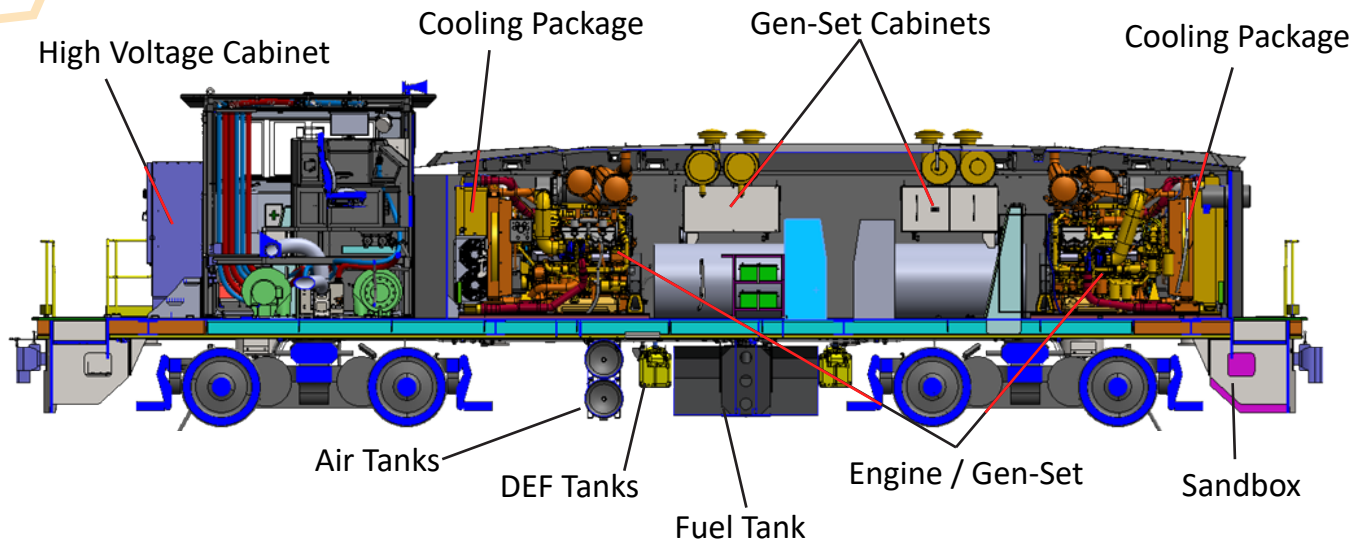

All configurations comply with AAR Plate "C" Clearance Diagram

Photo Overview of Features



Lighting



Lighting



360 Degree Camera System



Operator Station



Hand Brake in Cab



Batteries

Engine Options

Prime Movers (Diesel Engines)

Integral dx provides you the option to best fit your locomotive power needs. The old saying, horsepower does not get you up a bigger hill, it climbs the bigger hill faster. A five Hp golf cart will pull a load up a steep hill, but not as fast as an F150 pickup. If you do not operate over 20 mph, then tractive effort might be more important than Hp. Short Line Railroads tell us that fuel is one of their top 5 expenditures every year, however, duty cycles of most switcher locomotives use far less than the peak power available, for well over half of the life of the machine. Why burn extra fuel all year long, when it is seldom required?

While others have unsuccessfully attempted to automate multi-engine systems, Integral dx understands all use cases are unique, and puts the ultimate control of the diesel engines in the hands of the operator. This assures engines are operated at the right loads and temperatures, crucial to year-over-year optimal engine performance. Together with a system that boasts complete functionality, independent of engine operation configuration, single or dual engine operation is as simple as electing to start one engine or two.

Integral dx has elected to utilize proven CAT engines in our family of Switcher Locomotives. These engines are supported worldwide, with trained technicians and access to service parts in your region.

AAR Intergrated Crash Posts

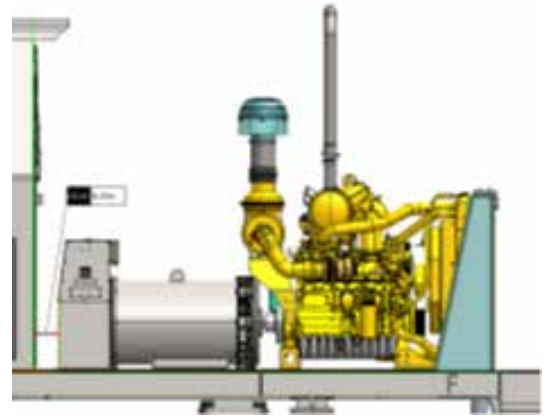

The CAT Tier 4f Engine is direct coupled to the Marathon Generator, with cooling direct driven off the front crank. Exhaust exits high above the shroud. Engine cooling is sized to handle 125 F ambient temperatures, and cold weather start options are available.

Removable louvred doors provide easy access for service & repairs

Left Side

AC Compressor

Fuel Filter



Oil Dipstick



Right Side

Coolant Supply

Coolant Return

Oil Filler Neck

Oil Filter

Oil Dipstick

Oil Drain





CAT 9.3B, Tier 4f

900 Hp Prime Mover (456 Hp x Qty 2)

The Cat® C9.3B is an inline six-cylinder, 9.3-liter engine system with 18 percent more power compared to previous engines. Ratings on this platform run from 335 to 456 horsepower at speeds of 1,800 to 2,200 rpm, with max torque at 1,400 rpms measuring 1,540 foot-pounds. The engines meet the requirements of the EPA Tier 4 Final and EU Stage V emissions regulations. A single ECM controls the engine, fuel and after treatment, rather than multiple control units. The new ECM also has about 13 times more processing power than previous systems and a two-wire Ethernet.



CAT C13B, Tier 4f

1000 Hp Prime Mover (500 Hp x Qty 2)

The Cat® C13B engine supplies remarkable power and torque in a smaller, lighter engine package. With an aftertreatment that is 65% smaller and 54% lighter than its current equivalent and over 34 kW/L of power density, the C13B is designed to allow OEMs to downsize their engine platforms, lower installation costs and maximize uptime by providing long life in the toughest applications. The diesel engine is an inline six-cylinder, with single turbocharger-after cooled (TA) arrangement is offered in ratings ranging from 456-577 hp. These ratings meet U.S. EPA Tier 4 Final emission standards.



CAT C18, Tier 4f

1600 Hp Prime Mover (800 Hp x Qty 2)

The Cat® C18 industrial diesel engine is an inline six-cylinder, with single turbocharger-after cooled (TA) arrangement is offered in ratings ranging from 575-800 hp. These ratings meet U.S. EPA Tier 4 Final emission standards.



CAT C27, Tier 4f

1800 - 2100 Hp Prime Mover (900 - 1050 Hp x Qty 2)

The Cat® C27 is a V12 Industrial Diesel Engine has ratings ranging from 800-1050 hp @ 1800 rpm. The C27 has a dual-can diesel oxide catalyst (DOC) after treatment that eliminates the need for diesel exhaust fluid (DEF). It also has a fuel consumption that is optimized to match the operating cycles of a wide range of equipment.

Press Release Caterpillar:

“The Caterpillar C-Series engines from the C9.3 to C32 model are manufactured in the United States. There are versions available for the level of emissions engines dedicated to rail vehicles, which is very important in the context of the use primarily in locomotives.”

Generator

Since 1913, Marathon Electric has been dedicated to providing customers with quality products for targeted applications. Located in Wausau, Wisconsin, the company is composed of two strategic product lines: motors and generators. Marathon headquarters remain in Wausau, Wisconsin, with approximately 550 employees. The company's customer care team is located there, along with engineering, finance, HR, and accounting.

Since its market introduction, Marathon Electric's MAGNAMAXDVR® has been a technology leader and proven performer. The MAGNAMAXDVR® generator line offers as standard a permanent magnet generator excitation system, exceptional transient performance and strong motor starting capability, and utilizes the industry's first digital voltage regulator.

Fully Guarded for operator safety and generator protection, no rotating or electrically energized parts are exposed. All openings are covered by louvers or screens, in addition to the engine enclosure of the locomotive.



*Generators pictured may not exactly represent those installed in your Locomotive.
Standard Marathon Warranty (See Warranty for Details): 12 Months. Extended Warranty may be available depending on model, contact Integral dx for details.
Detail specifications for each Marathon model available on the Marathon web sites, www.marathongenerators.com.
Kato and other brand options available upon request.*

Tractive Effort

Machine Weight	Machine Weight (Tons)	Starting Tractive Effort	Traction Motors	Gear Ratio	Wheel Type
164,000	82	41,000	D77/D78	62:15	FAT 40
240,000	120	60,000	D77/D78	62:15	FAT 40
280,000	140	70,000	D77/D78	62:15	FAT 40
360,000	180	84,000	D77/D78	62:15	FAT 40

*Tractive Effort actuals may vary due to rail conditions

Truck Assemblies & Traction Motors



All sizes of our locomotive family utilize the AAR switcher trucks or optional Blomberg B (swing hanger) trucks with EMD D77/D78 traction motors. This is the only part of our family where we integrate refurbished parts. The assembly is so proven and so widely understood, it simply makes \$ sense to integrate this proven work horse.

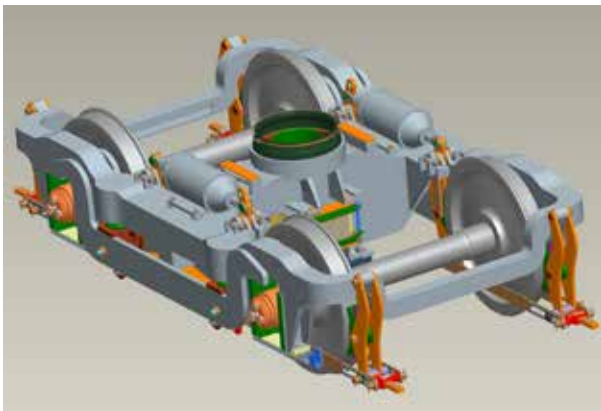

Optional Blomberg B (swing hanger) trucks



NEW: Brakes & Rigging, Suspension, Rotating Bearings-Journals, Hardware-Pins-Bushings, Bolster Ring, Wheels.

REFURBISHED: Motor-Axle, Frames, Brake Air Cylinders. Details upon request

Gearing	62/15, 4.133:1 Standard 65/12, 5.416:1 Optional
Motor Peak Torque	6,000 Ft-lbs
Motor Continuous Torque	4,400 Ft-lbs
Wheel Diameter	40 Inch
Braking	Clasp Brakes, Twin Shoe
Hand Brake	Standard Manual; Optional Motorized
Leaf Springs	Heavy (Standard 220,000-300,000 lbs), Light (Optional <220,000 lbs)
Flange Lubrication	Optional

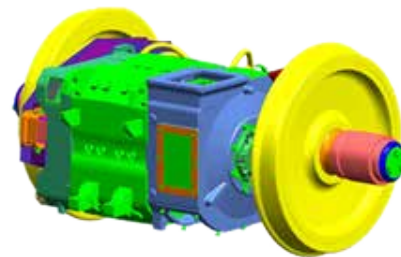

Traction Controls

Connecting the Generator to the Traction Motors is accomplished via TMV Control Systems and American Traction Systems (ATS). The TMV Traction Engine Control Unit (TECU), an intuitive system that is easy to navigate and operate so that you can get the most out of your locomotive. Installed inside your high voltage Electrical Cabinet, the TECU I/O modules receive input from contactors, relays, current sensors, fuel level, pressure sensors, and oil sensors. TMV is integrated with the ATS DC propulsion with features including: Motor Thermal Overload Protection, Adjustable Overcurrent Protection, Single-Dual-or-Triple Genset Systems, Compact Modular Construction, and Automatic Wheel Slip Control.

At commissioning, Integral dx can customize the throttle notch max amperage to the motors, as well as the ramp rate to max amperage, for each of the 8 notches. This will allow each delivered locomotive to be set-up for users unique needs.

Passenger Train Package: Our 8 notch controls are software defined. You can adjust speed and acceleration for each notch, allowing for “no spilled wine” control. We also offer “softer braking” to give 100% comfort to your passengers on both ends of the trip.

Industrial Train Package: We call this the “Get-R-Done” configuration. More aggressive notch acceleration and speeds, with typical heavier braking, to get your work finished on-time.



Engine & Auxiliary Custom Controls



Main Display Screen



Lighting



HVAC



Aux Display



Generator Status



Engine 1 Info

Key Components

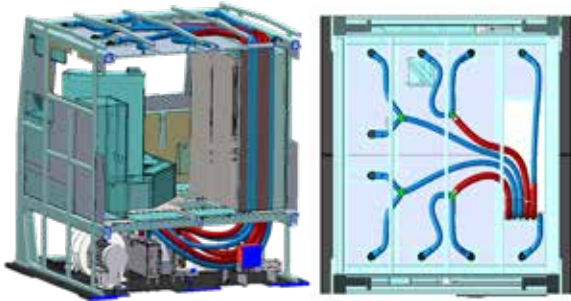

HVAC

DTAC 811 Evaporator - Qty 2
Cooling Capacity: 36,000 Btu/hr ea.
(72,00 Btu / hr total)
Heating Capacity: 38,700 Btu / hr ea.
(77,400 Btu / hr total)



Atlas Copco

CFM: 119.5 @ 138 PSI, before the Dryer
29.3kw (480VAC 60HZ)
1183 lbs
1375 L x 770 W x 1065 H



Sand Boxes

Sand boxes provided on all 4 corners.
Directional controls provide sanding in the
direction of travel only. Sanding is
automatically activated during emergency
braking.



Multi Unit MU

AAR S-512 27 pin industry standard MU system
MU receptacle and dummy receptacle provided
on both ends for connection cable storage.

Rail Duty Pyle National Receptacles Standard
Isolate / Run cab controls configuration
AAR S-5529 compliant MU brake equipment



New York Air Brake

The CCB-26 electro-pneumatic control unit (EPCU) is
mounted in the locomotive brake bay. It consists of
modularized line replaceable units (LRUs) that control
the development of all pneumatic control pressures.



Optional Sliding Coupler

Sliding coupler allows for tight radius turns
to be navigated while pulling or pushing cars

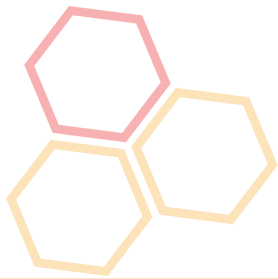

Past Rail Projects

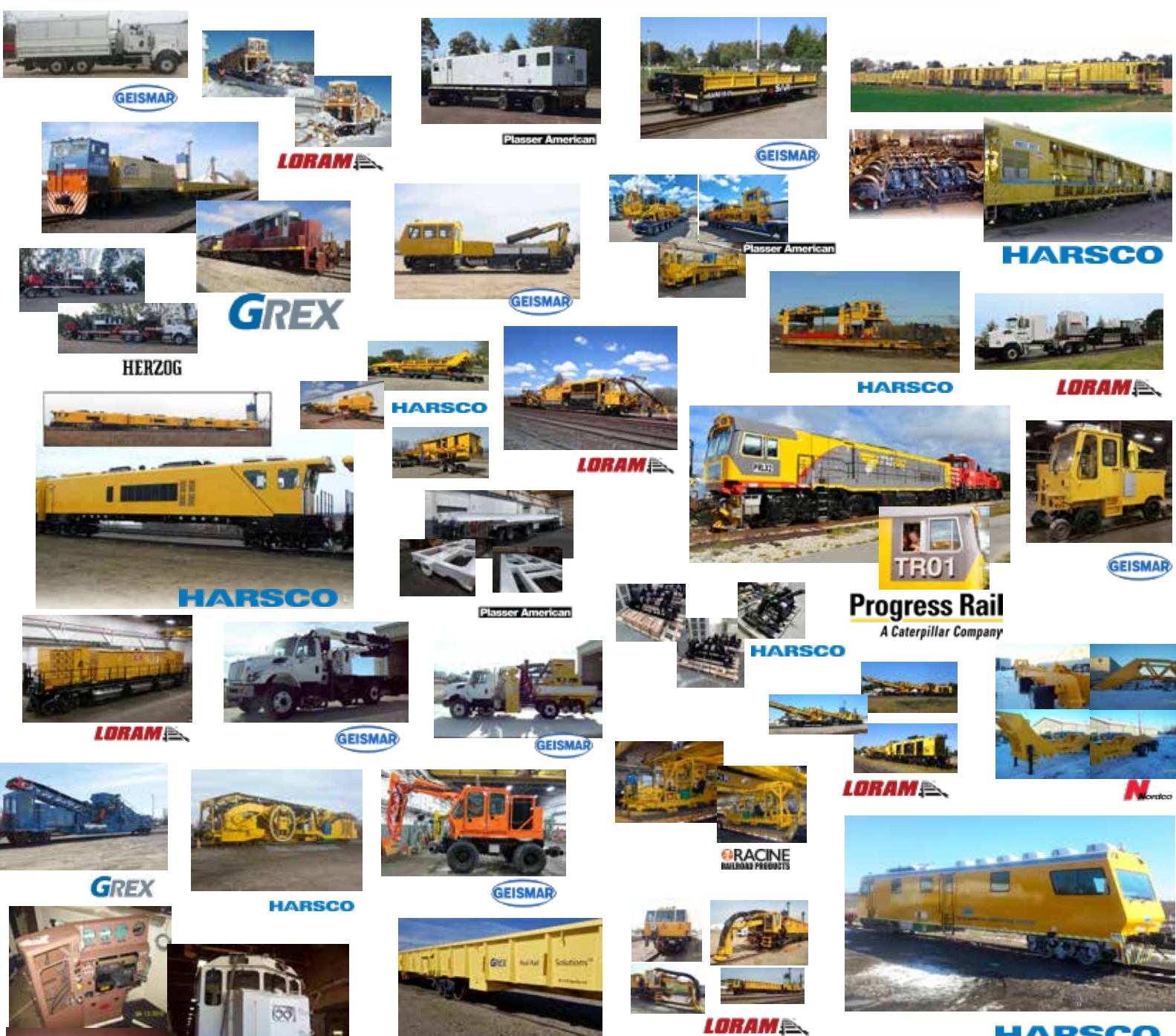

The above provides you a sample of our Past 28 Years of Rail Projects

Use of Logos does not infer partnership



www.integraldx.com
121 N 1st. Street
Montevideo, MN 56265
(320) 435-0003

